

DTT-11/18/23 DYNAMIC TUMBLE DRYERS



TOUCH II

User friendly and totally programmable 4'3" Touch II (option 7"screen)
 USB Connection. PC software free of charge for programming, traceability, data analysis...
 Videos on display (ads, instructions, etc.)
 37 languages



OUTSTANDING FEATURES

Reversing drum action as standard
 Stainless steel drum as standard
 Frequency inverter as standard



EFFICIENCY

DOUBLE FLOW - mixed axial-radial airflow
 Big fluff filter



VERSATILITY

Make to order - customisation
 WET CLEANING
 OPL > Multivending - Standard OPL model easily trasformable to coin laundry uses



CONNECTIVITY

Remote technical service
 Management of laundries: OPL and COIN
 Remote payment



ERGONOMICS

Drawer as fluff filter, made of stainless steel
 Biggest door diameters
 Opening sense of door adjustable on site



MAINTENANCE

Hinged panel: easy and ergonomic access
 Technical menu: statistics, alarm, autotest, data recovery for technicians and maintenance



OTHERS

Grey skinplate outer casing, stainless steel look
 Transmission by direct drive
 SOFT DRY - new drum with stamped holes
 COOL DOWN - anti-wrinkle at the end of the cycle
 Heating options: electric, gas and steam
 CE approved



OPTIONS

- EFFICIENT DRY - Intelligent humidity control with new drum inlet temperature control
- Option 7" touch screen
- Double doorglass
- Reverse door opening
- SFEX - Integrated Fire Extinguishing System
- New dosing/vaporizing system
- Printer
- DomusConnect communication kit
- Tropicalized model
- Stainless steel AISI 304 outer casing
- Stainless steel AISI 304 front panel
- Stainless steam battery
- Low pressure steam battery
- Wooden packing
- Exhaust silencer Ø200
- Rear panel external air + filter
- Ship voltage for electric models: 440V III 50/60 Hz No neutral

TECHNICAL DATA	UNIT.	DTT-11 DYNAMIC		DTT-18 DYNAMIC		DTT-23 DYNAMIC	
CAPACITY							
Capacity 1/18	Kg	12		18		26	
Capacity 1/20	Kg	11		17		23	
Hourly Output DYNAMIC*	Kg/h	28,6		31,9		40,6	
Evaporation capacity DYNAMIC*	l/h	14,5		16,3		20,4	
DRUM							
Ø Drum	mm	750		750		855	
Ø Door	mm	574		574		574	
Door center height	mm	976		976		1.030	
Load hole bottom height	mm	689		689		743	
Drum length	mm	475		746		800	
Drum volume	l	210		330		460	
POWER							
Drum motor power	Kw	0,37		0,37		0,37	
Fan motor power DYNAMIC	Kw	0,25		0,25		0,55	
Electric heating power ALL RANGES	Kw	12		18		24	
Total electric power (elec.model) DYN	Kw	12,67		18,67		24,97	
Gas heating power ALL RANGES	Kw	20,51		20,51		31	
Total electric power (gas model) DYN	Kw	0,67		0,67		0,97	
Steam heating power ALL RANGES	Kw	30		30		49,2	
Steam heating power (gas model) DYN	Kw	0,67		0,67		0,97	
CONNECTIONS		ELECTRICAL	STEAM / GAS	ELECTRICAL	STEAM / GAS	ELECTRICAL	STEAM / GAS
Tension 230V - I + N + T	N° x mm2 / A	3 x 35 / 63A	3 x 1,5 / 20A	-	3 x 1,5 / 20A	-	3 x 1,5 / 20A
Tension 230V - III + T	N° x mm2 / A	4 x 10 / 40A	3 x 1,5 / 20A	4 x 16 / 63A	3 x 1,5 / 20A	4 x 25 / 80A	3 x 1,5 / 20A
Tension 400V - III + N + T	N° x mm2 / A	5 x 4 / 25A	3 x 1,5 / 20A	5 x 10 / 32A	3 x 1,5 / 20A	5 x 10 / 40A	3 x 1,5 / 20A
Ø Gas inlet	BSP	1/2"		1/2"		1/2"	
Ø Steam inlet	BSP	3/4"		3/4"		1"	
Ø Condensed (Steam models)	BSP	3/4"		3/4"		1"	
DIMENSIONS / PACKING DIMENSIONS							
Net Width / Gross Width	mm	785 / 865		785 / 865		890/970	
Net Depth / Gross Depth	mm	855 / 940		1.125 / 1.210		1.255/1.345	
Net Height / Gross Height	mm	1.694 / 1.840		1.694 / 1.840		1.812/1.940	
Height without heating battery	mm	-		-		-	
Net weight / Gross weight	Kg	172 / 180		187 / 200		210/230	
OTHERS							
Max airflow DYNAMIC	m3/h	850		850		1.200	
Ø Fume exhaust	mm	200		200		200	
Sound level DYNAMIC	dB	64		64		65	

* It may vary depending on the type of heating, filter cleanliness or extraction type.

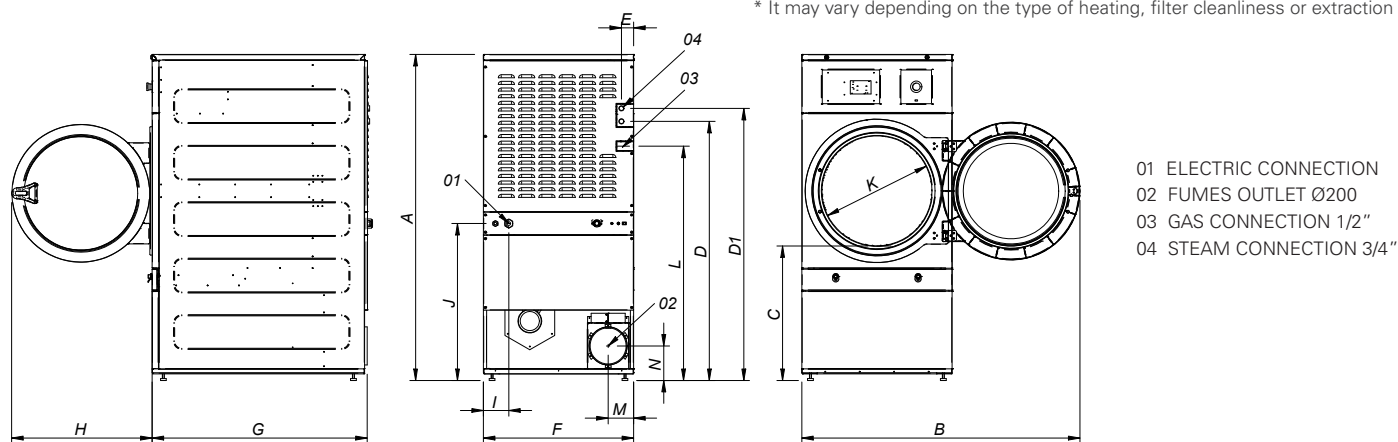

	A	B	C	D	D1	E	F	G	H	I	J	K	L	M	N
DTT-11	1694	1447	689	1354	1422	68	785	855	735	95	821	575	1226	133	180
DTT-18	1694	1447	689	1354	1422	68	785	1125	735	95	821	575	1226	133	180
DTT-23	1812	1552	743	1430	1532	112	890	1255	735	205	862	575	1344	133	180